

REV. NO	TARİH	DEĞİŞİKLİK NEDENİ	YAPAN	ONAY

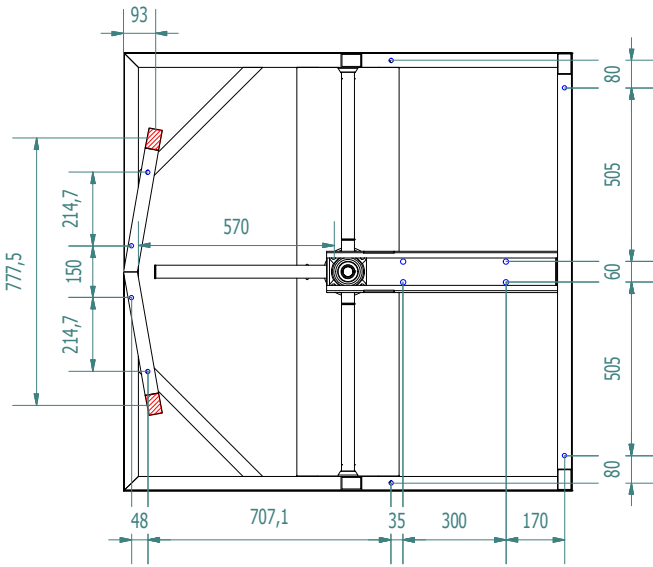
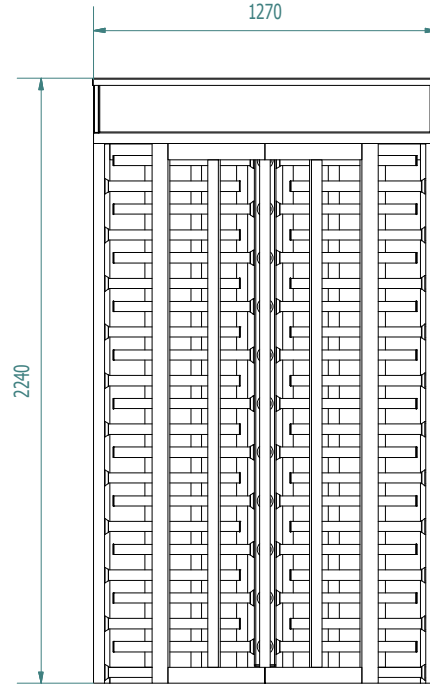
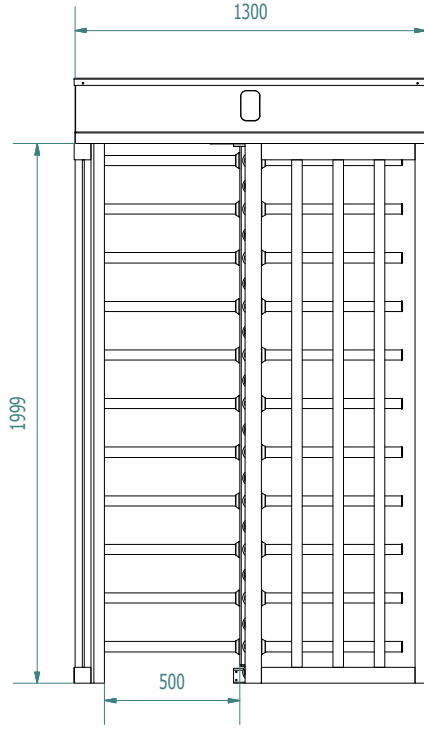

O Kablo Geçiş Alanı / Wiring Inlet Zone

A- MAX. Ø40mm PVC kablo kanalı kullanın.

A- Use PVC conduit Ø40mm MAX.

B- Enerji kablosu (230VAC) _ 3x2,5mm² topraklı kablo.

B- Mains power cable (230VAC) _ 3G2,5².

C- Kart okuyucu kablosu _ Kullanılan okuyucudan bilgi alınız.

C- Card reader cable _ From access control system.

D- Yangın alarm/ buton kablosu _ LIYCY 8x0,25mm².

D- Fire alarm/ push button cable _ LIYCY 8x0,25².

o Yer Bağlantı Noktası / Fixing Points

A- Ø14mm delik delinecek. 100mm derinliğinde M8 saplama için.

A- Drill Ø14mm & 100mm deep for M8 threaded rod.

B- Kimyasal dübel (dondurucu) kullanın.

B- Use the chemical sealing.

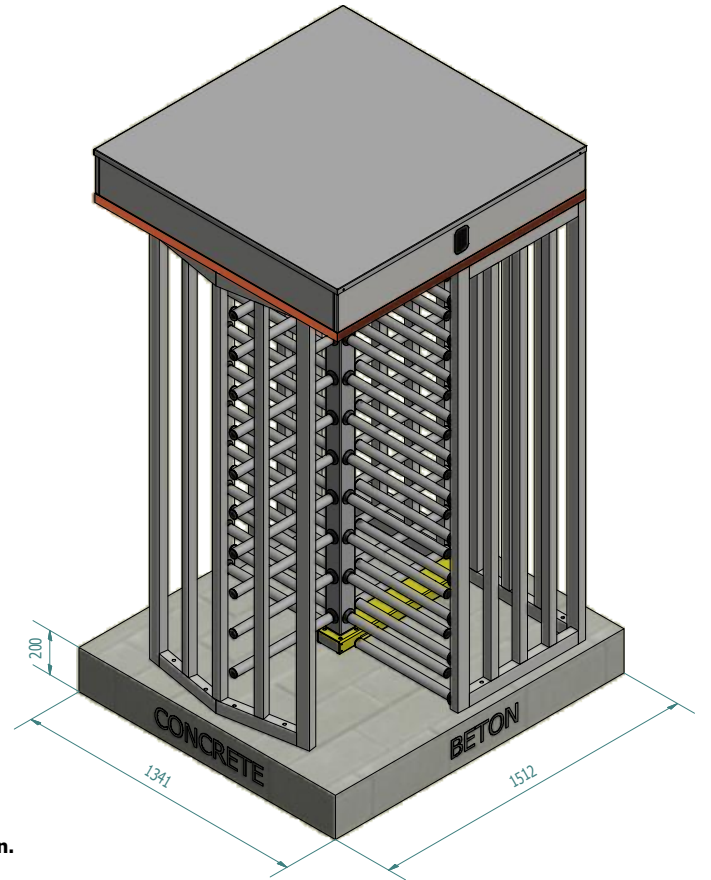

İSİM	TARİH	İMZA	PARÇA NO	DOSYA ADI	MALZEME	RESİM NO	GEN TOL	ÖLÇEK	SAYFA
YAPAN							±		
ÇİZEN									
ONAY									

T2500K 4 KOLLU

